

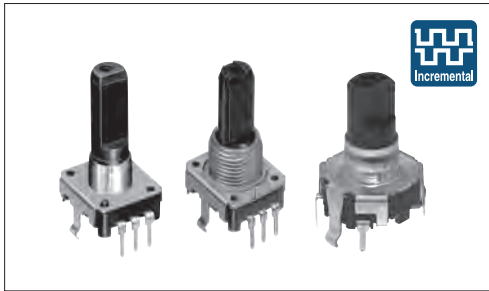

■ Typical Specifications



Items		Specifications
Rating		Each lead 0.5mA 5V DC Common lead 1mA 5V DC
Operating life	Without detent	Heavy: 15,000 cycles, Standard: 30,000 cycles
	With detent	30,000 cycles
Operating temperature range		EC12E: -10°C to +70°C EC12D: -40°C to +85°C

■ Product Line  
Standard Type

Length of the shaft LM <sub>1</sub> (mm)	Torque (mN·m)	Number of detent	Number of pulse	Minimum order unit (pcs.)		Product No.	Drawing No.		
				Japan	Export				
15	Standard 3 to 20	12	12	2,400	2,400	<b>EC12E1220407</b>	2		
20						<b>EC12E1220406</b>	1		
25						<b>EC12E1220405</b>	1		
8.5 (Through shaft)	Lightest (jog) 3±2			24	24	3,000	3,000	<b>EC12E1220301</b>	3
20								<b>EC12E1240405</b>	1
25								<b>EC12E1240406</b>	1
8.5 (Through shaft)	Standard 3 to 20	24	24			2,400	2,400	<b>EC12E1240301</b>	3
15								<b>EC12E24204A2</b>	2
17.5								<b>EC12E24204A7</b>	1
20	<b>EC12E24204A8</b>								
25	<b>EC12E24204A9</b>			3					
8.5 (Through shaft)	Lightest (jog) 3±2				24	24	3,000	3,000	<b>EC12E2420301</b>
20		<b>EC12E24404A8</b>	1						
25		<b>EC12E24404A6</b>	1						
8.5 (Through shaft)	Standard 10 max.	Without	Without	2,400			2,400	<b>EC12E2440301</b>	3
20								<b>EC12E24104A6</b>	1
25								<b>EC12E2430404</b>	
25	Heavy 25±15			Without	Without	2,400	2,400	<b>EC12E2430401</b>	1
25	Heavy 25±15								

With Bushing Type

Length of the shaft LM <sub>1</sub> (mm)	Torque (mN·m)	Number of detent	Number of pulse	Minimum order unit (pcs.)		Product No.	Drawing No.
				Japan	Export		
25	Standard 3 to 20	12	12	1,900	1,900	<b>EC12E1220813</b>	4
20		24	24			<b>EC12E2420802</b>	
25						<b>EC12E2420801</b>	
30		<b>EC12E2420803</b>					
20	Heavy 25±15	Without	Without	1,900	1,900	<b>EC12E2430804</b>	4
25						<b>EC12E2430803</b>	
30						<b>EC12E2460802</b>	

Nuts and washers are not included. If required, please contact us.

Product Line

With Switch Type

Length of the shaft LM <sub>1</sub> (mm)	Detent torque (mN·m)	Number of detent	Number of pulse	Operating force of switch (N)	Travel of push-on switch (mm)	Minimum order unit (pcs.)		Product No.	Drawing No.
						Japan	Export		
175	5±3	30	15	3	0.5	1,280	2,560	EC12D1524403	5
	10±5							EC12D1564402	
	5±3			EC12D1524406					
	10±5			EC12D1564404					

Notes

EC12D is suitable for automotive use.





Packing Specifications

Tray

Product No.	Number of packages (pcs.)		Export package measurements (mm)
	1 case /Japan	1 case /export packing	
EC12E □□□ 03	3,000	3,000	525×369×204
EC12E □□□ 04	2,400	2,400	
EC12E □□□ 08	1,900	1,900	
EC12D	1,280	2,560	540×360×290

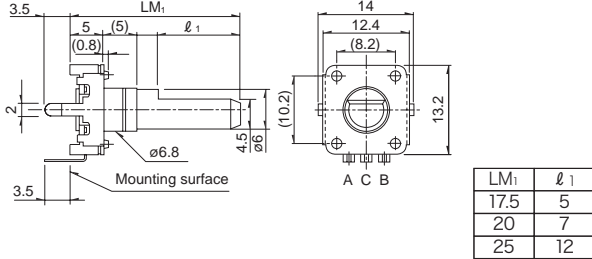
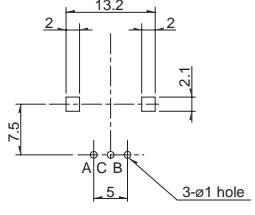
Dimensions

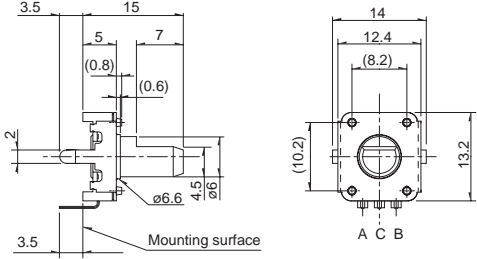
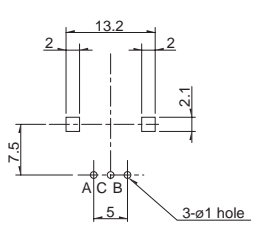
Unit:mm

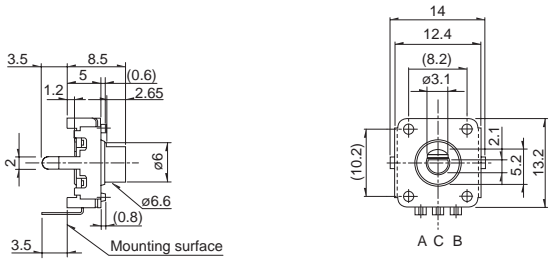
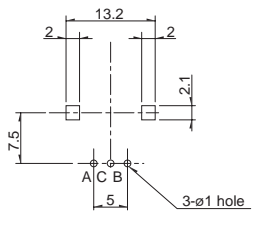
No.	Photo	Style	PC board mounting hole dimensions (Viewed from mounting side)								
1		 <table border="1" data-bbox="981 1339 1101 1433"> <thead> <tr> <th>LM<sub>1</sub></th> <th>ℓ<sub>1</sub></th> </tr> </thead> <tbody> <tr> <td>17.5</td> <td>5</td> </tr> <tr> <td>20</td> <td>7</td> </tr> <tr> <td>25</td> <td>12</td> </tr> </tbody> </table>	LM <sub>1</sub>	ℓ <sub>1</sub>	17.5	5	20	7	25	12	
LM <sub>1</sub>	ℓ <sub>1</sub>										
17.5	5										
20	7										
25	12										
2											
3											



Refer to P.257 for switch specifications.  
Refer to P.275 for soldering conditions.

# EC12E EC12D

## 12mm Size Insulated Shaft Type

### Dimensions

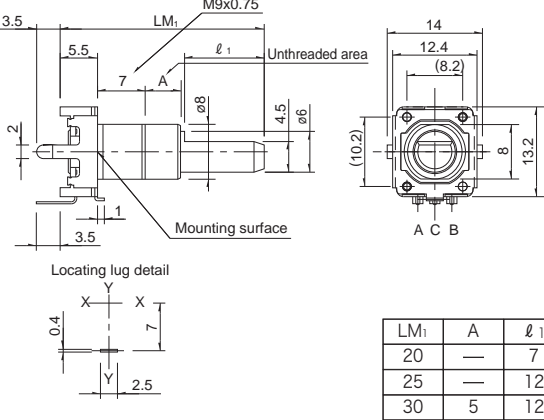
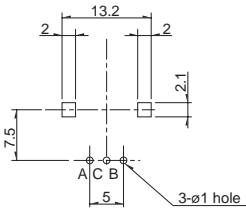
Unit:mm

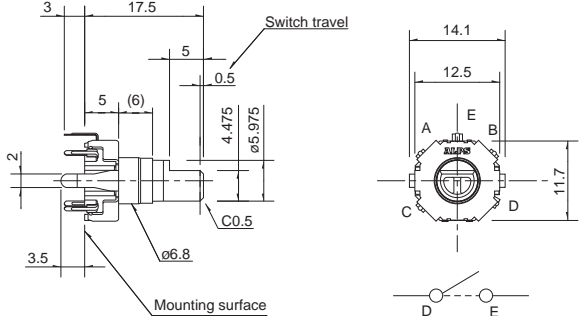
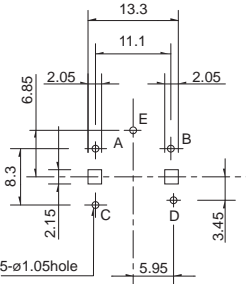
No.	Photo	Style	PC board mounting hole dimensions (Viewed from mounting side)												
4		 <table border="1" data-bbox="922 698 1104 801"> <thead> <tr> <th>LM1</th> <th>A</th> <th>l1</th> </tr> </thead> <tbody> <tr> <td>20</td> <td>—</td> <td>7</td> </tr> <tr> <td>25</td> <td>—</td> <td>12</td> </tr> <tr> <td>30</td> <td>5</td> <td>12</td> </tr> </tbody> </table>	LM1	A	l1	20	—	7	25	—	12	30	5	12	
LM1	A	l1													
20	—	7													
25	—	12													
30	5	12													
5	 														

### Output Wave

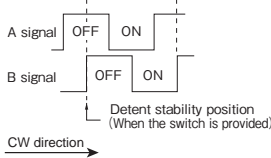
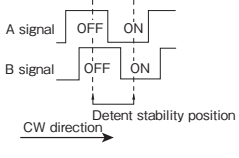
EC12E	EC12D
 <p>Detent stability position (When the switch is provided)</p> <p>CW direction →</p> <p>*Detent position cannot be specified for B signal.</p>	 <p>Detent stability position</p> <p>CW direction →</p>

### Sliding Noise

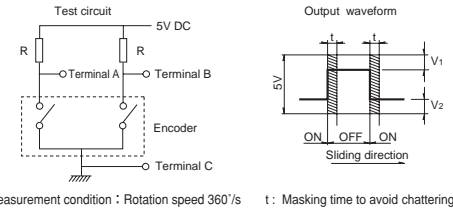
EC12E	EC12D
 <p>Test circuit: 5V DC, R, Terminal A, Terminal B, Encoder, Terminal C</p> <p>Output waveform: V1, V2, Sliding direction, ON, OFF, ON</p> <p>Measurement condition: Rotation speed 360°/s t: Masking time to avoid chattering</p>	<p>EC12E</p> <p><math>V_1 = V_2 = 1.5V</math> max. At <math>R = 10k\ \Omega</math> Chattering: 3ms max. Bounce: 2ms max.</p> <p>EC12D</p> <p><math>V_1 = V_2 = 2.5V</math> max. At <math>R = 5k\ \Omega</math> Chattering: 3ms max. Bounce: 2ms max.</p>

# 12mm Size Insulated Shaft Type / Product Varieties

In addition to the Product Line, we accommodate the following specifications. Combinations not included in the Product Line are treated as semi-standard products.

## ■ Shaft Dimensions

Flat Type: EC12E

Unit:mm

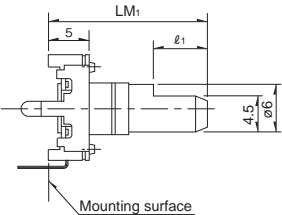
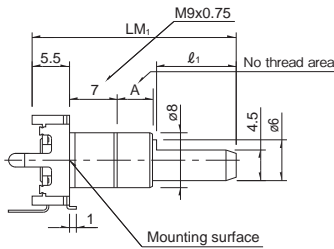
<p><b>High collar type</b></p> 	<p>Detailed dimensions</p> <table border="1" data-bbox="1061 369 1289 548"> <thead> <tr> <th><math>LM_1</math></th> <th><math>l_1</math></th> </tr> </thead> <tbody> <tr> <td>17.5</td> <td>5</td> </tr> <tr> <td>20</td> <td>7</td> </tr> <tr> <td>22.5</td> <td>7</td> </tr> <tr> <td>25</td> <td>12</td> </tr> <tr> <td>30</td> <td>12</td> </tr> </tbody> </table> <p>※ Not available for types without detents</p>	$LM_1$	$l_1$	17.5	5	20	7	22.5	7	25	12	30	12			
$LM_1$	$l_1$															
17.5	5															
20	7															
22.5	7															
25	12															
30	12															
<p><b>With bushing type</b></p> 	<p>Detailed dimensions</p> <table border="1" data-bbox="1061 660 1359 806"> <thead> <tr> <th><math>LM_1</math></th> <th>A</th> <th><math>l_1</math></th> </tr> </thead> <tbody> <tr> <td>20</td> <td>—</td> <td>7</td> </tr> <tr> <td>25</td> <td>—</td> <td>12</td> </tr> <tr> <td>30</td> <td>5</td> <td>12</td> </tr> <tr> <td>35</td> <td>5</td> <td>12</td> </tr> </tbody> </table> <p>Excluding the 12 detent type</p>	$LM_1$	A	$l_1$	20	—	7	25	—	12	30	5	12	35	5	12
$LM_1$	A	$l_1$														
20	—	7														
25	—	12														
30	5	12														
35	5	12														

Encoders

Metal Shaft

Insulated Shaft

Through Shaft Type









Ring Type

# 12mm Size Insulated Shaft Type / Switch Specifications

Switch type	Momentary push switch	
Contact arrangement	Single pole and single throw (Push-on)	
Travel (mm)	0.5±0.3	
Operating force	3 ± 1.5 N, 6 ± 2.5 N	
Operating life	30,000 times	
Electrical performance	Rating	1mA 5V DC (10mA 5V DC max. ratings)
	Contact resistance	100mΩ max. for initial period, 200mΩ max. after operating life.
	Insulation resistance	100MΩ min. 250V DC
	Voltage proof	300V AC for 1 minute or 360V AC for 1 second

# Encoders

## List of Varieties

Type		Metal shaft	Insulated shaft		
		11mm size	12mm size		18mm size
Series		<b>EM11B</b>	<b>EC12E</b>	<b>EC12D</b>	<b>EC18A</b>
Photo					
Output		Incremental (Two phase A and B)			Absolute type
Shaft types		Single-shaft			
Control part orientation		Vertical			
Number of pulse / Number of detent		16/16	12/12 24/24 24/without	15/30	12 positions 15 positions 16 positions
Features		Magnetic type	—	With push-on switch	Water resisting performance (IPX7)
Dimensions (mm)	W	10.8	12.4	12.5	18.8
	D	11	13.2	11.7	18
	H	7.5	5		8.75
Operating temperature range		-30°C to +85°C	-10°C to +70°C	-40°C to +85°C	-20°C to +60°C
Operating life		1,000,000 cycles	15,000 cycles 30,000 cycles	30,000 cycles	
Automotive use		●	—	●	—
Life cycle (availability)					
Electrical performance	Rating	10mA 5V±5% DC	0.5mA 5V DC	1mA 5V DC	1mA 10V DC
	Max./min. operating current (Resistive load)	15mA / —	5mA / 0.5mA	10mA / 1mA	—
	Insulation resistance	100MΩ min. 100V DC	10MΩ min. 50V DC	100MΩ min. 250V DC	10MΩ min. 250V DC
	Voltage proof	250V AC for 1 minute or 300V AC for 2s	50V AC for 1 minute	300V AC for 1 minute or 360V AC for 1s	50V AC for 1 minute or 60V AC for 2s
Mechanical performance	Rotational torque (Without detent)	—	10mN·m max. 25±15mN·m 40±15mN·m	—	—
	Detent torque	10±5mN·m	3±2mN·m 3 to 20mN·m	5±3mN·m 10±5mN·m	60±20mN·m
	Push-pull strength	100N	80N	100N	Push 100N / Pull 50N
Shaft configuration		Flat	Flat, Through shaft	Flat	
Terminal type		Insertion			
Switch Specifications	Switch type	Push-on switch	—	Push-on switch	—
	Contact arrangement	Single pole and single throw (Push-on)	—	Single pole and single throw (Push-on)	—
	Travel (mm)	0.5 ± <sub>0.2</sub> <sup>0.3</sup>	—	0.5±0.3	—
	Operating force (N)	5.5±3	—	3 <sub>-1</sub> <sup>+1.5</sup>   6 <sub>-2</sub> <sup>+2.5</sup>	—
	Rating	5mA 5V DC (50mA 12V DC max. ratings)	—	1mA 5V DC (10mA 5V DC max. ratings)	—
	Contact resistance	500mΩ max. for initial period, 5mΩ max. after operating life.	—	100mΩ max. for initial period; 200mΩ max. after operating life.	—
	Operating life	1,000,000 times	—	30,000 times	—
Page		252	254	255	258

Encoders Soldering Conditions	275
Encoders Cautions	276

### Notes

● Indicates applicability to all products in the series.

## Reference for Manual Soldering

Series	Tip temperature	Soldering time	No. of solders
EC05E, EC09E, EC10E, EC111, EC11E, EC11M, EC11N, EC12D, EC12E, EC18A, EC21A, EC28A, EC35A, EC35AH, EC40A, EC50A, EM11B, EC21C, EC28C, EC35CH	350°C max.	3s max.	1 time

## Reference for Dip Soldering

Series	Preheating		Dip soldering		No. of solders
	Soldering surface temperature	Heating time	Soldering temperature	Soldering time	
EC09E, EC111, EC11E, EC11M, EC11N, EC18A, EC21A, EC28A, EC35A, EC35AH, EC50A	100°C max.	2 min. max.	260±5°C	5±1s	2 times max.
EM11B	100°C max.	1 min. max.	260°C max.	3s max.	2 times max.
EC10E, EC12D, EC12E	100°C max.	1 min. max.	260±5°C	3±1s	2 times max.
EC40A	110°C max.	1 min. max.	260°C max.	10s max.	1 time

## Example of Reflow Soldering Condition

Temperature profile

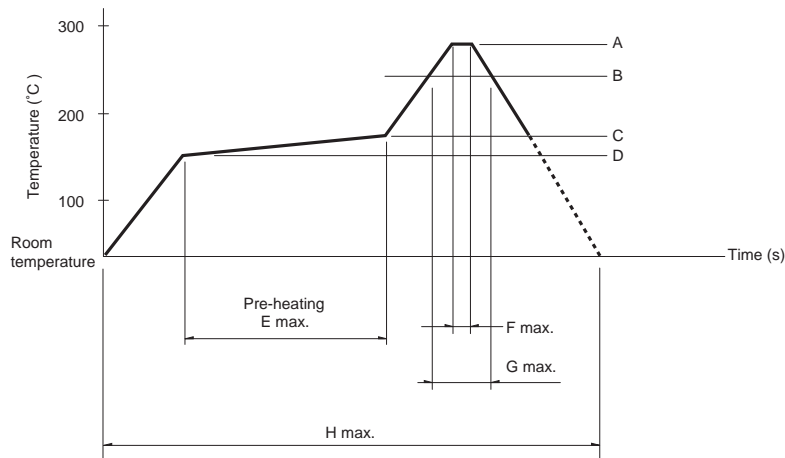

Series	A	B	C	D	E	F	G	H	No. of reflows
EC05E	250°C min.	230°C min.	180°C	150°C	60s to 120s	—	30s to 40s	—	2 times max.
EC21C	230°C to 245°C	220°C	200°C	150°C	60s to 120s	—	25s to 60s	300s max.	1 time max.
EC28C, EC35CH	260°C	230°C	180°C	150°C	2 min. min.	3s	40s	230s max.	1 time max.

### Notes

1. When using an infrared reflow oven, solder may sometimes not be applied. Be sure to use a hot air reflow oven or a type that uses infrared rays in combination with hot air.
2. The temperatures given above are the maximum temperatures at the terminals of the encoder when employing a hot air reflow method. The temperature of the PC board and the surface temperature of the encoder may vary greatly depending on the PC board material, its size and thickness. Ensure that the surface temperature of the encoder does not rise to 250°C or greater.
3. Conditions vary to some extent depending on the type of reflow bath used. Be sure to give due consideration to this prior to use.